

序号	名称/规格	品牌/型号	规格
V-1	NONRECNALATURE 截止阀	CHART CHINA	
V-2	TOP FILL VALVE	WORCESTER 4044/48PSE	1/2" FNPT
V-3	LIQUID USE VALVE	REGO #T83844/48AB	3/8" FNPT
V-4	GAS USE VALVE	REGO #T9644A/48P-H/ARQ	3/8" FNPT
V-5	VENT/FULL TRYCOCK VALVE	REGO #T9644A/48P-H/ARQ	3/8" FNPT
V-6	PRESS. BLOC VALVE	REGO #T9644A/48P-H/ARQ	3/8" FNPT
V-7	VALVE BALL DVW	REGO #T9644A/48P-H/ARQ	3/8" FNPT
V-8	LIQUID PHASE	REGO #T9644A/48P-H/ARQ	3/8" FNPT
V-9	VAPOR PHASE	REGO #T9644A/48P-H/ARQ	3/8" FNPT
V-10	EQUALIZER	REGO #T9644A/48P-H/ARQ	3/8" FNPT
V-11	REG. ISO VALVE PB	REGO #T9644A/48P-H/ARQ	3/8" FNPT
V-12	VALVE VACUUM GAUGE TUBE	REGO #T9644A/48P-H/ARQ	3/8" FNPT
L	LEVEL INDICATOR	REGO #T9644A/48P-H/ARQ	3/8" FNPT
PG	PRESS. INDICATOR	REGO #T9644A/48P-H/ARQ	3/8" FNPT
R-1	PRESS. DRG/G. ECONO REG.	REGO #T9644A/48P-H/ARQ	3/8" FNPT
CV-1	TOP FILL CHECK VALVE	REGO #T9644A/48P-H/ARQ	3/8" FNPT
RV-12	RELIEF VALVE	REGO #T9644A/48P-H/ARQ	3/8" FNPT
RV-3	LINE RELIEF VALVE	REGO #T9644A/48P-H/ARQ	3/8" FNPT
RPD-12	RUP/TURE DISC. 1.1	REGO #T9644A/48P-H/ARQ	3/8" FNPT
VR-1	VACUUM READOUT	REGO #T9644A/48P-H/ARQ	3/8" FNPT
VP-1	VACUUM PUMP/OUT	REGO #T9644A/48P-H/ARQ	3/8" FNPT

名称	规格	品牌/型号	规格
WELD MATERIAL	碳钢 SAW	碳钢 SAW	
NDT	无损检测	无损检测	
HEAT TREATMENT	热处理	热处理	
INSULATION	保温层	保温层	
LEAKAGE TEST	泄漏测试	泄漏测试	
STATIC EVAPORATION RATE	静态蒸发率	静态蒸发率	
OUTER JACKET DISPOSAL	外筒处理	外筒处理	
INNER VESSEL PRESSURE	内筒压力	内筒压力	

名称	规格	品牌/型号	规格
WELD MATERIAL	碳钢 SAW	碳钢 SAW	
NDT	无损检测	无损检测	
HEAT TREATMENT	热处理	热处理	
INSULATION	保温层	保温层	
LEAKAGE TEST	泄漏测试	泄漏测试	
STATIC EVAPORATION RATE	静态蒸发率	静态蒸发率	
OUTER JACKET DISPOSAL	外筒处理	外筒处理	
INNER VESSEL PRESSURE	内筒压力	内筒压力	

名称	规格	品牌/型号	规格
WELD MATERIAL	碳钢 SAW	碳钢 SAW	
NDT	无损检测	无损检测	
HEAT TREATMENT	热处理	热处理	
INSULATION	保温层	保温层	
LEAKAGE TEST	泄漏测试	泄漏测试	
STATIC EVAPORATION RATE	静态蒸发率	静态蒸发率	
OUTER JACKET DISPOSAL	外筒处理	外筒处理	
INNER VESSEL PRESSURE	内筒压力	内筒压力	

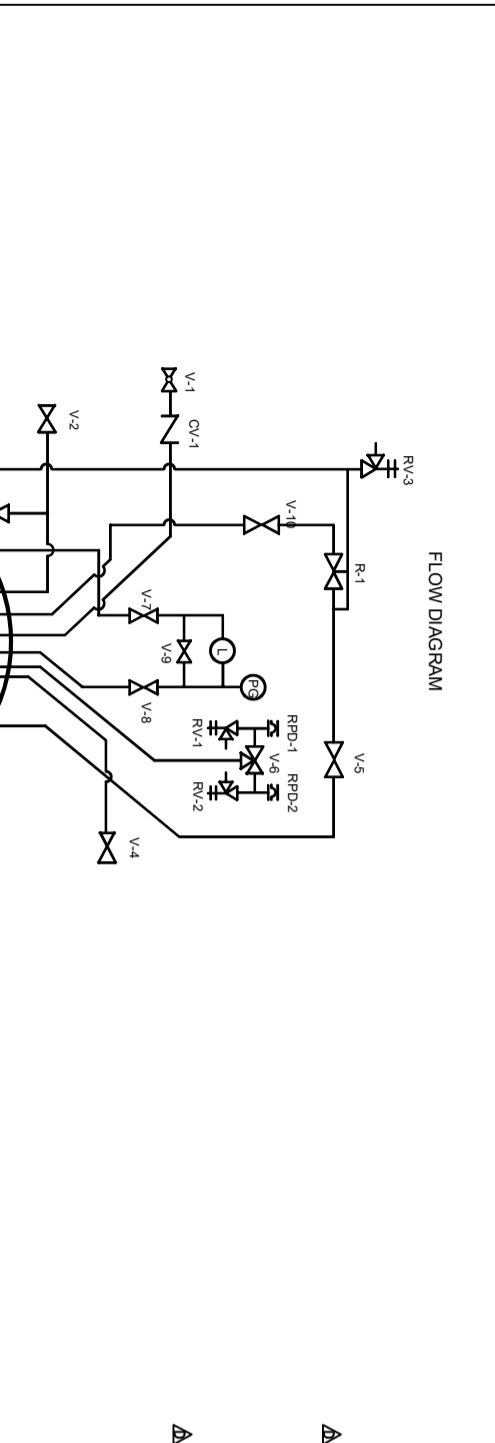

名称	规格	品牌/型号	规格
WELD MATERIAL	碳钢 SAW	碳钢 SAW	
NDT	无损检测	无损检测	
HEAT TREATMENT	热处理	热处理	
INSULATION	保温层	保温层	
LEAKAGE TEST	泄漏测试	泄漏测试	
STATIC EVAPORATION RATE	静态蒸发率	静态蒸发率	
OUTER JACKET DISPOSAL	外筒处理	外筒处理	
INNER VESSEL PRESSURE	内筒压力	内筒压力	

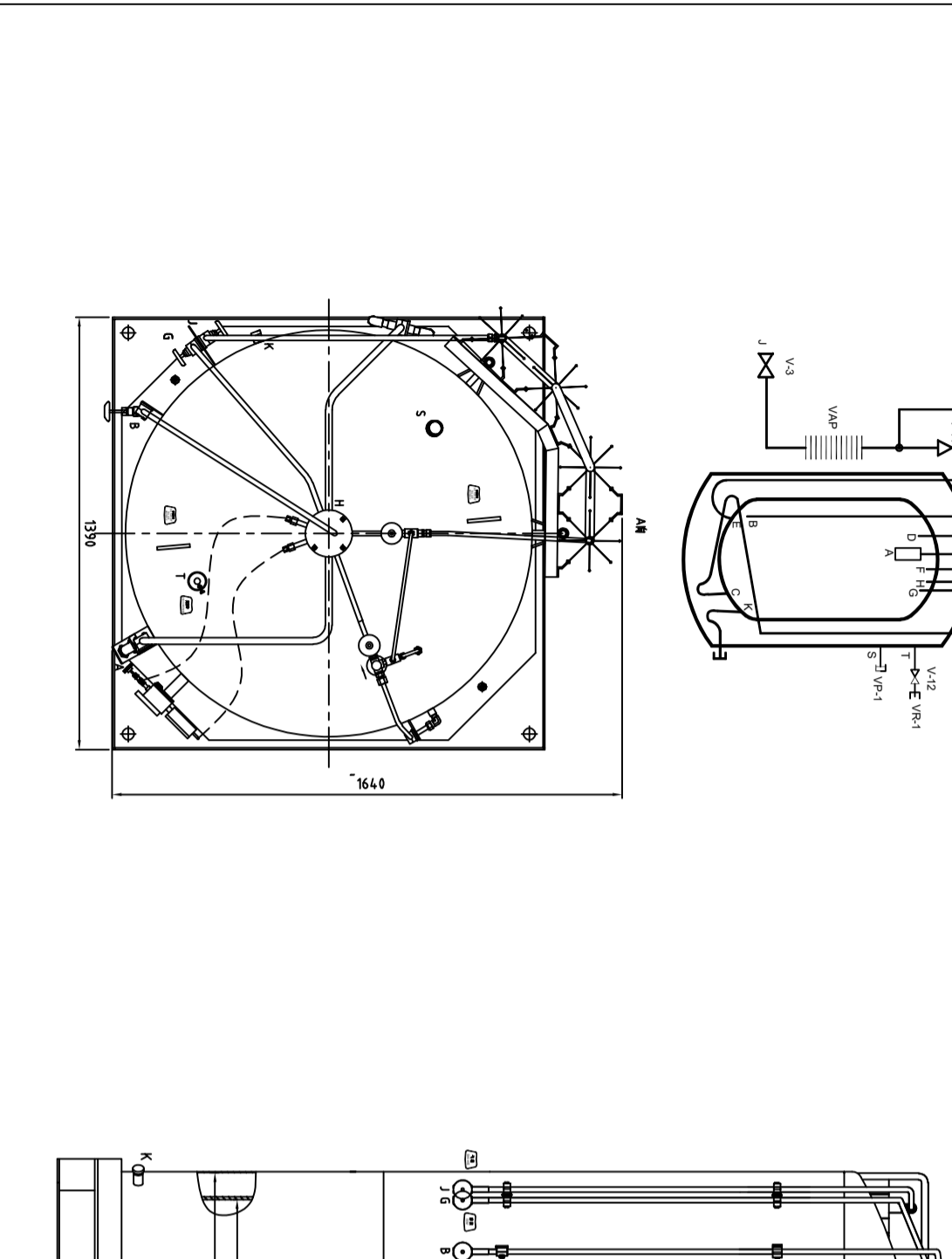

符号	名称	规格	品牌/型号	规格
A	1/2"	NPT 1/2	碳钢 SAW	
B	3/8"	NPT 3/8	碳钢 SAW	
G	3/8"	NPT 3/8	碳钢 SAW	
H	1/2"	NPT 1/2	碳钢 SAW	
J	3/8"	NPT 3/8	碳钢 SAW	
K	1/2"	NPT 1/2	碳钢 SAW	
S	2"	NPT 2	碳钢 SAW	
T	1/8"	NPT 1/8	碳钢 SAW	

名称	规格	品牌/型号	规格
WELD MATERIAL	碳钢 SAW	碳钢 SAW	
NDT	无损检测	无损检测	
HEAT TREATMENT	热处理	热处理	
INSULATION	保温层	保温层	
LEAKAGE TEST	泄漏测试	泄漏测试	
STATIC EVAPORATION RATE	静态蒸发率	静态蒸发率	
OUTER JACKET DISPOSAL	外筒处理	外筒处理	
INNER VESSEL PRESSURE	内筒压力	内筒压力	